

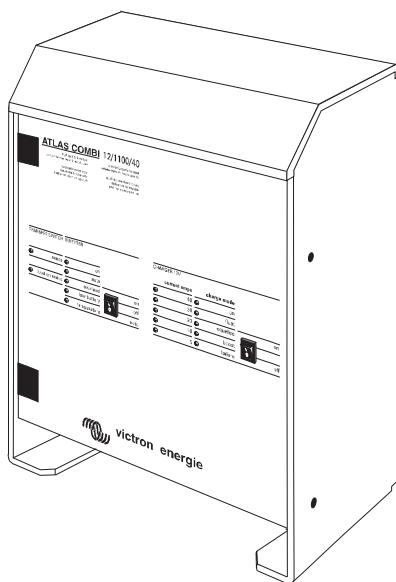

victron energie

VICTRON ATLAS COMBI



12/1100, 12/1500, 24/1800



This page intentionally left blank.



SECTIONS

ENGLISH
NEDERLANDS
DEUTSCH

This page intentionally left blank.



USER MANUAL

Victron Atlas Combi

12/1100

12/1500

24/1800

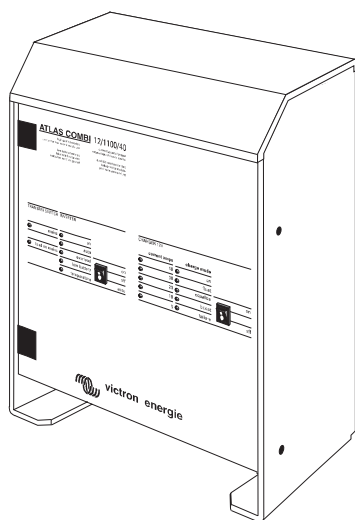

ENGLISH

This page intentionally left blank.



INTRODUCTION



Victron Energie has established an international reputation as a leading designer and manufacturer of power systems. Our R&D department is the driving force behind this reputation as it is continually seeking new ways of incorporating the latest technology in our products. Each step forward results in value-adding technical and economical features.

Our proven philosophy has resulted in a full range of state-of-the-art equipment for the supply of electrical power that meets the most stringent requirements.

Victron Energie systems provide you with high-quality AC supplies in places where there are no permanent sources of mains power.

An automatic stand-alone power system can be created with a configuration comprising a Victron Energie inverter, battery charger, mains manager (if required) and, last but not least, batteries with sufficient capacity.

Our equipment is suitable for countless situations in the field, on ships or other places where a mobile 230-Volt AC power supply is indispensable.

Victron Energie has the ideal power source for all kinds of electrical appliances used for household, technical and administrative purposes, including instruments susceptible to interference. All of these applications require a high-quality power supply in order to function properly.

Victron Atlas Combi

This manual contains directions for installing the Atlas Combi models 12/1100, 12/1500 and 24/1800. It describes the functionality and operation of the Atlas Combi, including its protective devices and other technical features.

This page intentionally left blank.



TABLE OF CONTENTS



1. DESCRIPTION	11
1.1 General	11
1.2 Description	11
1.3 Battery charger	12
1.4 Inverter	13
1.5 Changeover	13
1.6 Charging	14
2. PROTECTIVE DEVICES	17
2.1 Short-circuits	17
2.2 Maximum power	17
2.3 Overload	17
2.4 Temperature	18
2.5 Low input voltage	18
2.6 High input voltage	19
2.7 Reversed polarity	19
3. COMPENSATED CHARGING	21
3.1 Connection of sensor	21
3.2 Battery temperatures up to +10 °C	21
3.3 Battery temperatures between +10 °C and +50 °C	21
3.4 High battery temperature	22
4. INSTALLATION	23
4.1 Materials required	23
4.2 Location	23
4.3 Connections	23
4.3.1 Earth	23
4.3.2 230 V _{AC} output	24
4.3.3 230 V _{AC} input	24
4.3.4 Battery	24
4.3.5 Battery cables	25
4.3.6 Starter battery	25
4.4 Jumpers general	25
4.5 Potentiometers general	26

5. START-UP	27
5.1 Operation	27
5.2 “On” position	28
5.3 “Auto” position	28
5.4 Changeover	28
5.4.1 Engaging 230 V mains	28
5.4.2 Disengaging 230 V mains	28
5.5 Charger	29
5.6 Adjustments	30
5.6.1 Inverter	30
5.6.2 Frequency	30
5.6.3 Output voltage	30
5.6.4 Switch-on sensitivity (AES)	31
5.7 Battery charger	31
5.7.1 Maximum charging current	31
5.7.2 Adjustment of voltage	31
5.7.3 Float	31
5.7.4 Equalize	32
5.8 Maintenance	32
6. GENERAL	33
7. SPECIFICATIONS	39
7.1 Inverter	39
7.2 Automatic Economy Switch (AES)	40
7.3 Battery charger	41
7.4 Mechanical data	42
7.5 General	42
8. DRAWINGS	43

1. DESCRIPTION

1.1 General

All Victron Atlas Combi units are tested to ensure correct functioning before leaving the factory. They are packed in shock-absorbing polystyrene and packed in sturdy cardboard boxes for secure transportation.

IP21=
protection against materials larger than 12 mm (for example a finger) and protection against vertically descending water-drops (condensation).

The Victron Atlas Combi is housed in a robust aluminium cabinet (IP21) suitable for floor or wall mounting. The AC output terminals, the DC battery terminals and the terminals for a remote control switch (if used) can be reached by opening the front of the cabinet with a screwdriver.

1.2 Description

The Atlas Combi is a compact combination of an inverter and an automatic battery charger, hence the name Atlas Combi. The coding of the Combi models is composed as follows:

example: Atlas Combi 24/1800:

24 = 24 V battery voltage

1800 = 1800 W continuous power

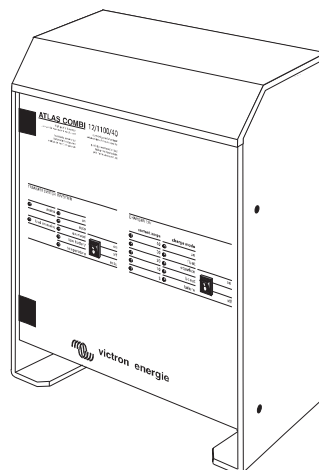

The Atlas Combi delivers a trapezoidal alternating current of 230 V, 50 Hz (see illustration 1). Continuous power can be delivered at all times. A maximum short-time power can be delivered for about one second.

	continuous power	maximum power
Atlas Combi 12/1100	1100 W	2000 W
Atlas Combi 12/1500	1500 W	2500 W
Atlas Combi 24/1800	1800 W	3500 W

Almost any electric or electronic device powered by a 230 V_{AC} (50 Hz) supply may be connected to the inverter of the Atlas Combi. Advanced electronic equipment may experience problems with the trapezoidal output voltage. We recommend the use of a Phoenix sinewave converter in these cases. Contact your supplier if you have any questions and/or problems.

1.3 Battery charger

The battery charger of the Atlas Combi is suitable for a 230 V (50 Hz) mains voltage. The charger works automatically and each model delivers a different maximum current as stated below.

	maximum current
Atlas Combi 12/1100	40 amp
Atlas Combi 12/1500	50 amp
Atlas Combi 24/1800	35 amp

The batteries may remain permanently connected to the charger, even during winter storage. The charger of the Atlas Combi was adjusted in the factory for the use of lead/acid batteries. The charger can also charge other types of batteries, such as traction and gel batteries. Contact your supplier for the adjustment of the charge voltage required for these batteries. Refer to section 3.1 for information on use of the temperature sensor. A starter battery may be connected to the second charger output. This charger can charge a starter battery with a maximum current of 2 amp.

starter battery =
a battery used only
to start
machines (such as
the engine of a boat)
and suitable for high
cold
currents

**semित्रaction
battery** =
a combined
starter/light battery

1.4 Inverter

The inverter converts a direct current of 12 V (or 24 V for the Atlas Combi 24/1800) into an alternating current of 230 V, 50 Hz. With the Atlas Combi switched on (i.e. switch set to “on”) the inverter’s own no-load power consumption is as stated below.

	no-load consumption	“AES” position
Atlas Combi 12/1100	20 W	2.4 W
Atlas Combi 12/1500	20 W	2.4 W
Atlas Combi 24/1800	25 W	2.4 W

A full-load efficiency of approximately 85% has been achieved through the use of FET transistors.

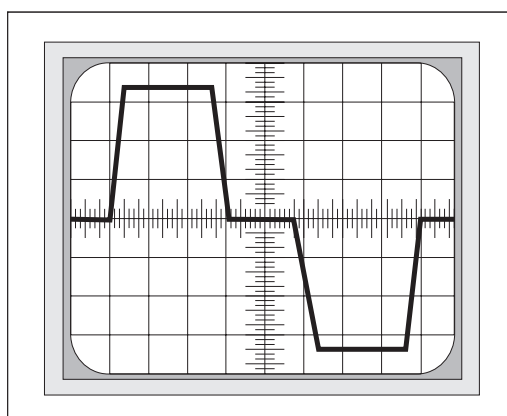

ill. 1 Output voltage

The Atlas Combi has a “stand by” facility. It is activated by setting the switch to the “auto” position. This switches the inverter to a lower stand-by voltage at times when the external equipment does not require power. This limits power consumption to 2.4 W and the inverter operates when a load is detected. Substantially reduced power consumption is achieved when there are intermittent loads.

1.5 Changeover

When a mains voltage is connected to the Atlas Combi, the green “mains” LED lights up. The load of the inverter is automatically switched to mains after about 30 seconds. This changeover is indicated by the yellow “load on mains” LED and the inverter is immediately switched off. More information about this changeover is given in section 5.4.

All models are capable of switching 16 amp resistive loads. The Atlas Combi is likely to be seriously damaged if this

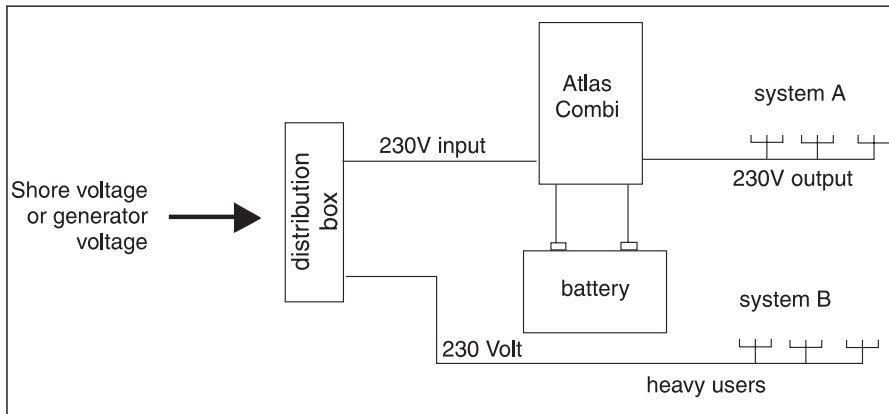

ill. 2 System for heavy users

value is exceeded. There is a special way of installing the Atlas Combi to ensure that heavy-duty equipment can run properly on shore or generator voltages without causing damage to the Combi.

Illustration 2 shows an Atlas Combi in combination with a system for heavy-duty equipment. System A is a group for various wall sockets and lighting, while system B receives power only if a shore or generator voltage is present.

Illustration 3 shows an Atlas Combi in combination with a Mains Manager. If you use a Mains Manager remote control panel in this set-up, some functions of the panel will not work. The potentiometer and the switch which activates the buffer system cannot be used because the charging output of the Mains Manager is not in service.

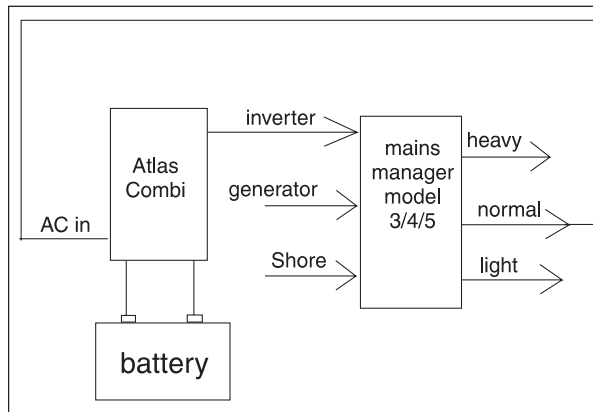

ill. 3 Combination with a Mains Manager

1.6 Charging

AC =
Alternating Current.
 This is the normal
 type of voltage
 supplied by the mains or
 shore power systems

DC =
Direct Current. This
 is the type of Voltage
 delivered by batteries
 and battery chargers.

The automatic part of the charger starts up about 10 seconds after the charger switch has been set to the “on” position and 230 V_{AC} is present. Charging takes place according to the IU_oU_o characteristic (see illustrations 4 and 5).

12 V battery voltage

The boost charging voltage (equalize) is set to a standard value of 14.25 V and the float charging voltage to a standard value of 13.5 V.

24 V battery voltage

The boost charging voltage (equalize) is set to a standard value of 28.5 V and the float charging voltage to a standard value of 26.5 V.

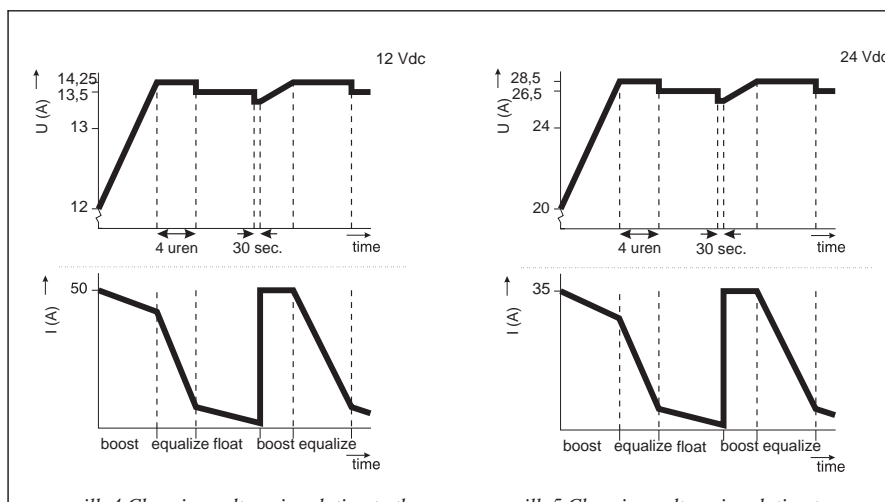

ill. 4 Charging voltage in relation to the voltage (12 Volt battery)

ill. 5 Charging voltage in relation to

This page intentionally left blank.



2. PROTECTIVE DEVICES



The Atlas Combi is extremely reliable thanks to numerous built-in protective devices. Descriptions of these devices are given below.

2.1 Short-circuits

The inverter's output is protected against short-circuiting. The short-circuit currents of the different models are stated in the table below.

	short-circuit current
Atlas Combi 12/1100	22 amp
Atlas Combi 12/1500	25 amp
Atlas Combi 24/1800	21 amp

short circuit current = current supplied when a short-circuit on the output occurs.

In this condition the output voltage approaches 0 V. Once the short-circuit has been rectified the inverter immediately resumes normal operation. This eliminates the need to fit a fuse in the inverter's output circuit.

2.2 Maximum power

The inverter delivers a maximum power as stated in the table below. This level is limited electronically and can be delivered for approximately one second.

	continuous power	maximum power
Atlas Combi 12/1100	1100 W	2000 W
Atlas Combi 12/1500	1500 W	2500 W
Atlas Combi 24/1800	1800 W	3500 W

2.3 Overload

If the inverter is subjected to a high load, it may reach the critical limit and the overload protection will be activated.

	overload protection operates at:
Atlas Combi 12/1100	approx. 1500 W
Atlas Combi 12/1500	approx. 2000 W
Atlas Combi 24/1800	approx. 3000 W

The overload protective device works as follows:

- When the critical limit is reached, the red “overload” LED flashes, the inverter switches off 20 seconds later and the LED stays on.
- If the load drops below the continuous power within 20 seconds, the inverter continues working normally and the “overload” LED goes out.
- If the inverter is switched off after 20 seconds and the load drops below the critical limit, it restarts after 30 seconds and full power can be delivered again.

LED =
Light Emitting
Diode

2.4 Temperature

The temperature of the electronics is measured continuously. The inverter switches off before the temperature reaches an unacceptably high level due to short-circuiting, overloading or excessive ambient temperatures. The “temperature” LED lights up when this situation occurs and the inverter restarts automatically once the temperature has dropped to an acceptable level.

2.5 Low input voltage

The inverter switches off if the input voltage is too low.

Input voltage of 12 V battery:

The minimum input voltage is approximately 9.5 V. The inverter restarts at a voltage higher than approximately 11 V.

Input voltage of 24 V battery:

The minimum input voltage is approximately 17.0 V. The inverter restarts at a voltage higher than approximately 22.5 V.

input voltage =
DC voltage
delivered by
batteries

output voltage =
AC voltage
delivered by the
Victron product

2.6 High input voltage

The inverter switches off if the input voltage is too high.

Input voltage of 12 V battery:

The inverter switches off if the input voltage rises above 17 V and restarts once the input voltage has dropped below approximately 15 V.

Input voltage of 24 V battery:

The inverter switches off if the input voltage rises above 33 V and restarts once the input voltage has dropped below approximately 31 V.

2.7 Reversed polarity

The Atlas Combi models are NOT protected against reversed polarity (i.e. “+” connected to “-” and “-” connected to “+”). Please follow the instructions given on page 43 carefully.

This page intentionally left blank.



3. COMPENSATED CHARGING

**V.T.S. =
Victron
Temperature
Sensor**

The Atlas Combi has a temperature compensation facility which adjusts the charger voltage to the battery temperature. To use this facility it is necessary to fit a temperature sensor (V.T.S.) to the battery. This is because a cold battery may be charged with a higher charging voltage than a warm battery.

12 V battery:

The reference charging voltage is 14.25 V at a battery temperature of 20 °C (see illustration 6).

24 V battery:

The reference charging voltage is 28.5 V at a battery temperature of 20 °C (see illustration 7).

3.1 Connection of sensor

To connect the temperature sensor, switch jumper S2 in "on" position ("1") and switch jumper S3 in "off" position ("0"). See section 4.4 and drawing AC03008e on page 48 for information on these jumpers.

3.2 Battery temperatures up to +10 °C

At temperatures up to +10 °C, the charger supplies a maximum charging voltage of:

12 V battery:	14.5 V
24 V battery:	29.0 V

This output voltage is limited because at higher voltages problems might occur in the external equipment (see illustration 6 and 7, section "B").

3.3 Battery temperatures between +10 °C and +50 °C

In this temperature range the output voltage depends on the battery temperature measured by the sensor. As the temperature increases the output voltage of the charger decreases (see illustration 6 and 7, section "C").

3.4 High battery temperature

At battery temperatures of +50 °C and higher the charging voltage drops sharply. At values of 51 °C and higher the charger operates as a rectifier with an output voltage of 12 V (or 24 V) (see illustration 6 and 7, section “D” and “E”).

The plastic bag containing connection materials includes instructions showing where the temperature sensor must be fitted. It is also necessary to change jumpers S2 and S3 on the control PCB (see section 8, drawing number AC03008E on page 46).

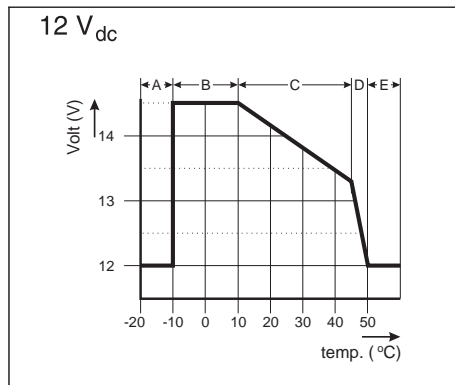

ill. 6 Output voltage in relation to the battery temperature (12 Volt battery).

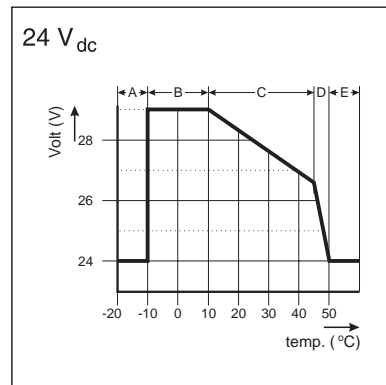

ill. 7 Output voltage in relation to the battery temperature (24 Volt battery).

4. INSTALLATION

4.1 Materials required

Screwdriver No. 1, socket spanner 10, 13, phillips screwdriver No. 2 and straight screwdriver No. 1.

4.2 Location

Install the inverter in a dry area with good ventilation.

NOTE: High ambient temperatures will reduce output power, impair efficiency and shorten working life (see specifications).

There are holes in the bottom and rear of the cabinet for floor or wall mounting. For the dimensions refer to section 8, drawing number AC03006E on page 45.

The Atlas Combi may be fitted to the wall or on a horizontal surface. Make sure there is sufficient ventilation to allow forced cooling. The front of the Atlas Combi is hinged to the left. Make sure you will have easy access to the inside of the unit after installation. Keep the distance between the Atlas Combi and the battery as short as possible.

4.3 Connections

4.3.1 Earth

Connect the mains earth wire to the earth terminal of the AC terminal block. An M4 earth screw is fitted in the bottom of the cabinet. Connect the cabinet earth to the vessel's hull or earth plate and in the case of motor vehicles to the chassis.

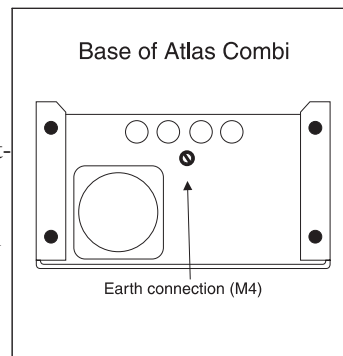

ill. 8.

4.3.2 230 V_{AC} output

The terminal block is located on the PCB. The 230 V external equipment must be connected to the inverter by means of a three-wire cable (see illustration 9). Use a cable with a flexible core and a wire diameter of 1.5 to 2.5 mm. The connection arrangement of the output terminal block is:

Phase:	Brown or Black wire to:	L1
Neutral:	Blue wire to:	N
Earth:	Yellow/Green wire to:	PE

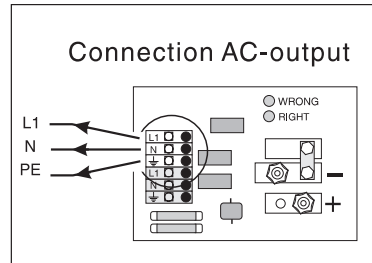

ill. 9 AC-output connection

4.3.3 230 V_{AC} input

A 230 V_{AC} supply is needed if the Atlas Combi's battery charger is used. Use a three-wire cable with a flexible core and wire diameter of 1.5 to 2.5 mm².

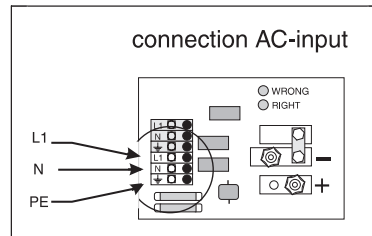

ill. 10 AC-input connection

The inverter will be damaged if another alternating-current (e.g. from a generator) is connected to the 230 V output.

4.3.4 Battery

The functioning and working life of equipment and batteries depends on the battery connections being made correctly. Between the battery and inverter there is a circuit with a low voltage and high current. As mentioned in section 2.7, the inverter is not protected against reversed polarity. Therefore you should carefully follow the connection instructions on page 47, drawing AC03009E.

Battery connections

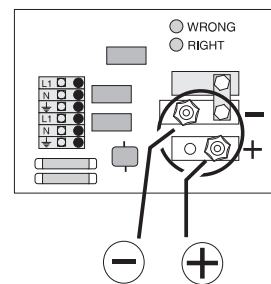

ill.11 DC-connection

4.3.5 Battery cables

The wire diameters of the battery cables are suitable for continuous loads and peak loads.

distances to batteries	cable diameter:
shorter than 1.5 m	25 mm
longer than 2.5 m and shorter than 4.0 m	35 mm
longer than 4.0 m and shorter than 6.0 m	50 mm

Avoid contact resistances by tightening up all connections.

4.3.6 Starter battery

Connect the starter battery to terminals 9 and 10 of the “remote” terminal blocks (9 is the “+” and 10 is the “-” of the battery). A wire thickness of 1.5 mm is sufficient to connect this battery.

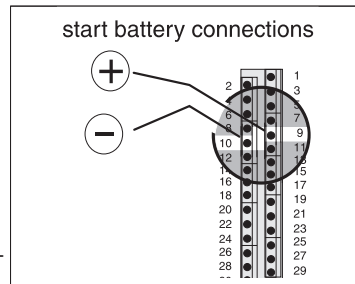

ill. 12 Connections starter battery.

4.4 Jumpers general

Jumpers are small removable connectors situated on the printed circuit board. By placing and removing the jumpers various features can be enabled or disabled. Illustration 13 shows how to set the jumpers.

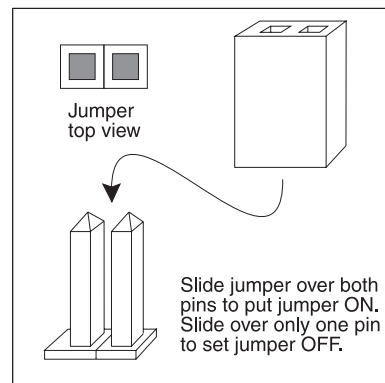

ill. 13 Jumpers placement

4.5 Potentiometers general

Potentiometers are adjustable resistors. Turning the screw increases or reduces the values associated within the potentiometer. Your supplier must adjust the potentiometers.

5. START-UP

5.1 Operation

The switches and LEDs of the inverter are located on the front of the Atlas Combi (see illustration 14).

inverter	=	inverter
mains	=	230 V _{AC} input voltage
load on mains	=	AC load switched at AC-output
on	=	switched on
auto	=	automatic (AES)
overload	=	overload indication
low battery	=	low input voltage
temperature	=	temperature indication
charger	=	charger
on	=	switched on
float	=	charging voltage when batteries are fully charged (trickle charging)
equalize	=	charging voltage at which batteries are properly recharged
boost	=	maximum charging
failure	=	temperature sensor defective

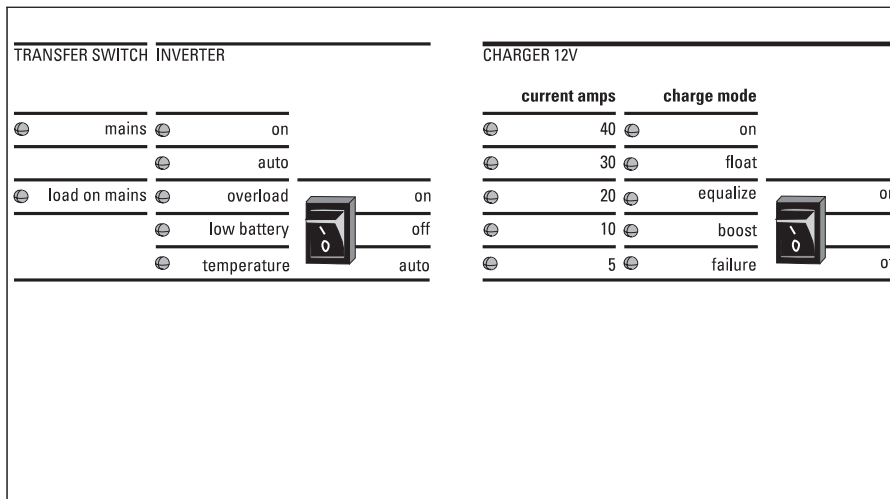

ill. 14 Front Atlas Combi

5.2 “On” position

Start the inverter by setting the “inverter” switch to the “on” position. The “on” LED lights up.

5.3 “Auto” position

When the inverter is in the “auto” mode (bottom position of the switch), the yellow “auto” LED lights up to indicate that the AES has been activated. Refer to the fault tracing list if this does not occur. The inverter starts as soon as the load at the output exceeds 9 W. The “auto” LED goes out and the green “on” LED lights up. The inverter switches back to the “auto” mode automatically as soon as the load is switched off. The yellow “auto” LED lights up again.

5.4 Changeover

5.4.1 Engaging 230 V mains

If the inverter is connected to the 230 V mains, the following sequence of events will occur:

1. The green “mains” LED lights up.
2. After about 30 seconds the load is switched from the inverter to the mains network. The yellow “load on mains” LED lights up.
3. The inverter switches off.
4. If the battery charger is switched to “on”, it will start to operate: The “on” LED lights up. The “equalize” LED lights up. About 10 seconds after the “equalize” LED lights up, all current-indicating LEDs light up.

5.4.2 Disengaging 230 V mains

If the 230 V mains voltage is switched off, the following sequence of events will occur:

1. The “load on mains” and “mains” LEDs go out and the battery charger is switched off.
2. If the inverter is switched to “on” or “auto”, the external equipment will be reconnected to a 230 V supply within 0.5 seconds.

5.5 Charger

The charger of the Atlas Combi is switched on by setting the “charger” switch to the “on” position. The “on” and “equalize” LEDs light up. The charger will not start to work for 10 seconds.

The charging current starts to rise a few seconds after the “equalize” LED lights up. This is indicated by the five “output current” LEDs on the front. The “boost” LED lights up if the batteries require more power than the charger can deliver.

The voltage rises gradually depending on battery capacity, discharge and consumption.

When the voltage reaches:

14.25 V (12 V battery) or

28.5 V (24 V battery)

the “equalize” LED lights up and the “boost” LED goes out.

At the same moment the charging current drops. This high charging current is maintained for four hours which ensures the optimum charging of the batteries. After this period the charger switches to a lower voltage of:

13.5 V (12 V battery) or

26.5 V (24 V battery).

The “float” LED lights up.

V.D.L. =
Victron trickle
charge system

**float charge
mode =**
recharging

**boost charge
mode =**
initial charging

The battery charger works with the VDL 2-step charging system made by Victron Energie. It automatically keeps the battery in a perfectly charged condition. External equipment has immediate access to power.

If during the float charge cycle the voltage drops below 13.5 V (12 V battery) or 26.5 V (24 V battery) for longer than 30 seconds, a new boost charge cycle is started. This may occur after the switching on of external equipment which requires more than 50 amp. A new charging cycle is also started if the charger is switched off briefly.

With the VDL system the battery charger can remain permanently connected to the battery without overcharging (gassing).

5.6 Adjustments

The internal adjustments should always be carried out by a qualified engineer.

The Victron Atlas Combi is preadjusted to the standard settings in the factory. In special cases it may be necessary to change the standard settings. Only qualified engineers recognized by Victron Energie may change these settings. The standard settings may have to be changed in the following instances.

- 240 V_{AC} for the United Kingdom instead of 230 V_{AC} for Europe.
- different charging voltages for traction batteries and other types of batteries.
- change the “auto” sensitivity.

The cabinet can be opened by unscrewing the four screws and opening the door (the door opens to the left). There are two PCBs on the inside of the door. They are the inverter control PCB and the charger control PCB (see illustration 15). Above the PCBs there are a number of potentiometers. The settings of the Combi are changed by turning the potentiometers.

5.6.1 Inverter

Adjust the frequency first if the frequency and the output voltage must be changed. If the frequency is changed, the output voltage will also change.

5.6.2 Frequency

The frequency is set to a standard value of 50 Hz although this can be altered by turning potentiometer R4 (see illustration 16) to the left (“-”) or to the right (“+”). The best way of measuring the frequency is by means of a reed type frequency meter or a Fluke 87 true RMS multimeter. Other meters produce measurement errors because the inverter has a trapezoidal output signal.

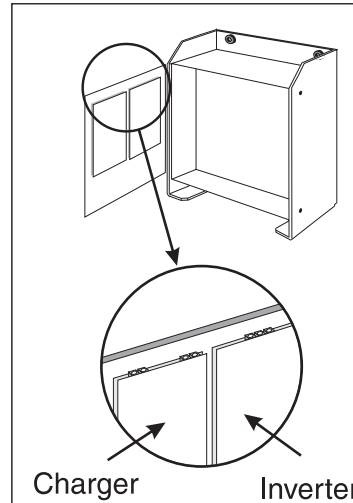

ill. 15 Opening the cabinet

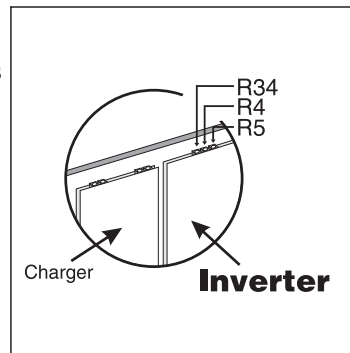

ill. 16 Potentiometers Atlas Combi

5.6.3 Output voltage

The output voltage has been preset to 230 V true RMS at zero load and 225 V at full load. The input voltage must be 12 (or 24) V. By turning potentiometer R5 (see illustration 16) to the left or right, the output voltage decreases and increases, respectively. The output voltage can be measured properly only with a true RMS meter because the output voltage is trapezoidal. The Fluke 87 multimeter is recommended.

5.6.4 Switch-on sensitivity (AES)

If the inverter does not switch from “auto” to “on” when a load is switched on, or if the inverter does not switch back to “auto” when there is no load, the AES sensitivity may be increased or decreased by turning potentiometer R34 to the right (“+”) or to the left (“-”). Check whether the inverter returns to “auto” or “on”.

5.7 Battery charger

5.7.1 Maximum charging current

The maximum charging current has been set by means of potentiometer R89 (farthest right) according to the table below.

	charging current
Atlas Combi 12/1100	40 A
Atlas Combi 12/1500	50 A
Atlas Combi 24/1800	35 A

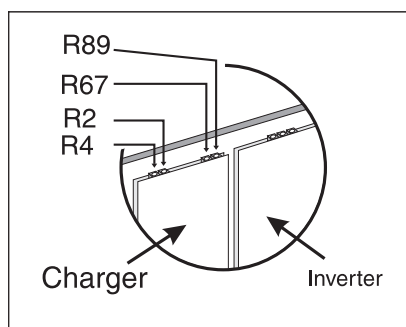

ill. 17 Potentiometers Atlas Combi (charger).

Measure this with a separate current meter. Switch on the charger and apply a load that creates an output voltage of 12 V. Turn potentiometer R89 until the correct current has been set. Do not set the current any higher than the maximum charging current for which the Combi has been designed. Higher currents will damage the Combi’s transformer.

5.7.2 *Adjustment of voltage*

The battery charger operates with two charging voltages which must be adjusted separately. First set the low charging voltage (float) and then the high charging voltage (equalize).

5.7.3 *Float*

The low charging voltage is adjustable by means of potentiometer R2 (the one on the left). Switch on the charger and disconnect all external equipment. Wait until recharging has finished and the yellow “float” LED lights. Connect a voltmeter with a reading accuracy of 0.1 V to the battery terminals. Turn potentiometer R2 until the correct voltage is set.

5.7.4 *Equalize*

The high charging voltage is adjustable by means of potentiometer R4 (farthest left). Switch on the charger. Wait until the batteries are charged to a level where the charging current is below 5 amp. The yellow “equalize” LED should now light. Connect a voltmeter with a reading accuracy of 0.1 V to the output of the charger. Turn potentiometer R4 until the correct voltage is set.

5.8 **Maintenance**

The Atlas Combi does not require any special maintenance. It is advisable to check the electrical connections periodically (once a year). Keep the converter as dry and clean as possible.

6. General

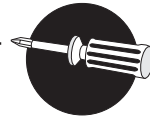

Always test the Combi without equipment, i.e. do not connect any users to the AC output and do not connect any 12 or 24 V_{DC} external equipment to the batteries.

The fault tracing lists cover the three parts which make up the Combi:

- inverter
- changeover unit
- charger

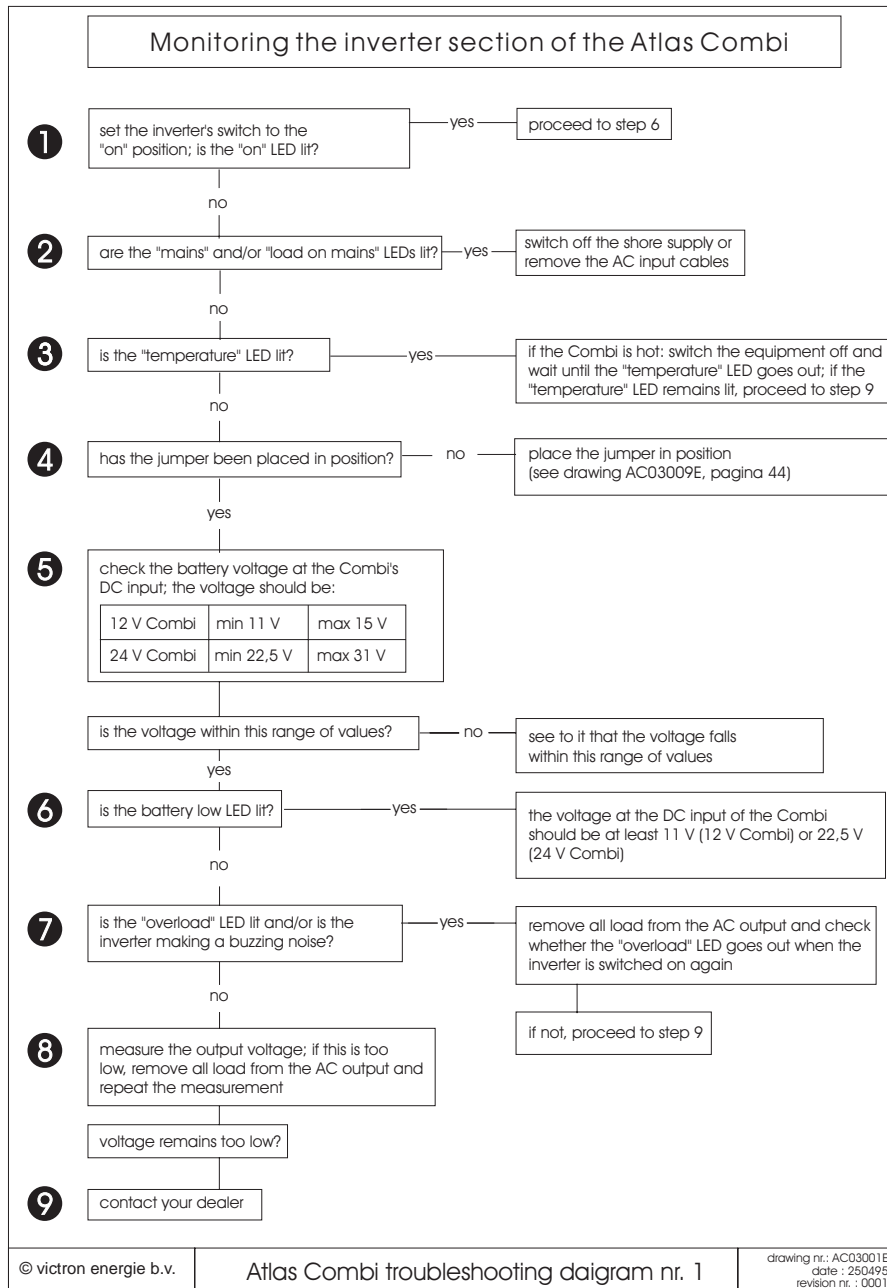

Monitoring the changeover section of the Atlas Combi

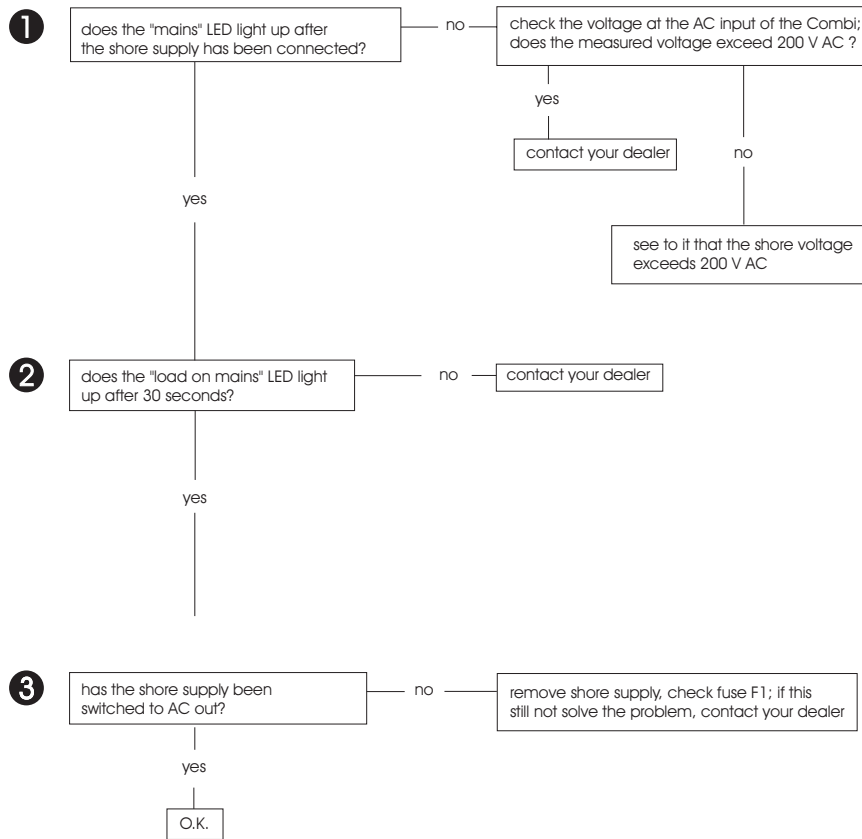

Monitoring the charger

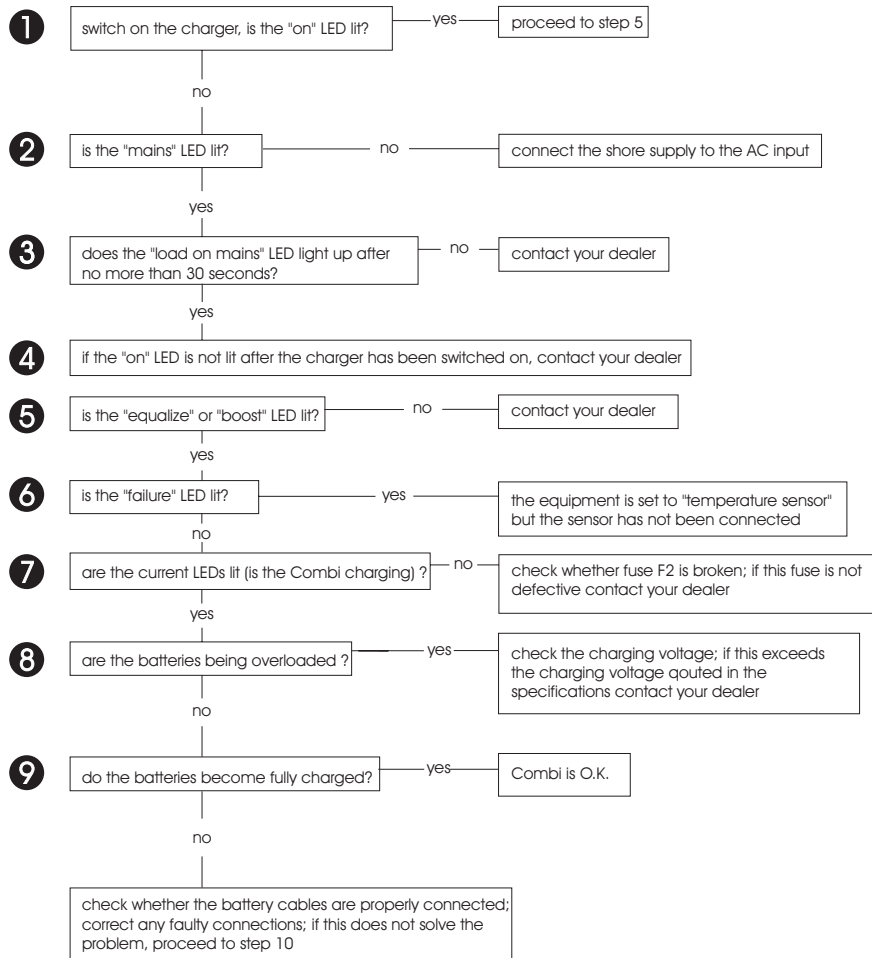

Monitoring the charger *(continued)*

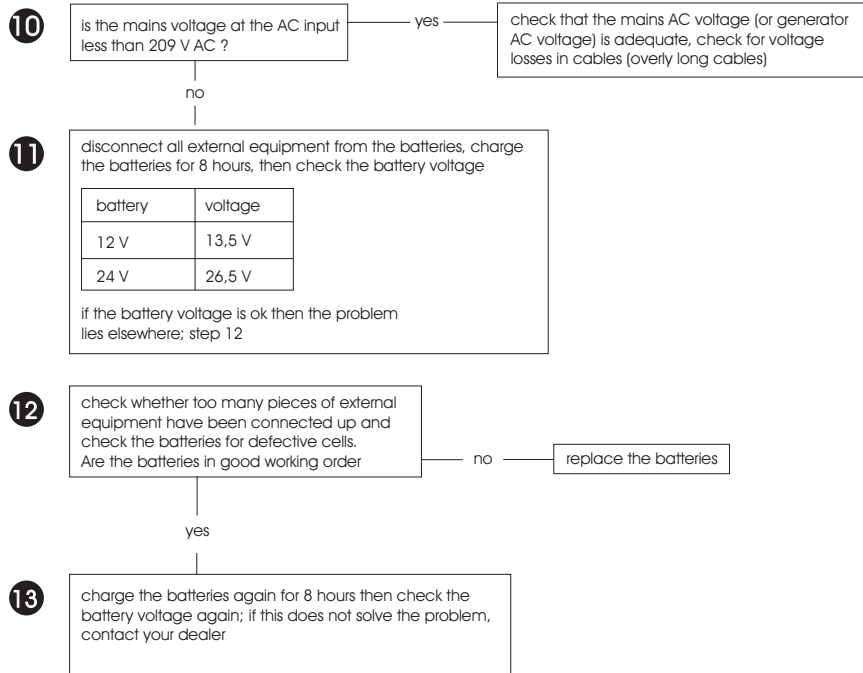

This page intentionally left blank.



7. SPECIFICATIONS

7.1 Inverter

Input

Nominal input voltage:

Atlas Combi 12/1100:	12 V _{DC}
Atlas Combi 12/1500:	12 V _{DC}
Atlas Combi 24/1800:	24 V _{DC}

Input voltage range:

Atlas Combi 12/1100:	9.5-17 V _{DC}
Atlas Combi 12/1500:	9.5-17 V _{DC}
Atlas Combi 24/1800:	17-33 V _{DC}

Voltage ripple: maximum 5% RMS

Nominal input current:

Atlas Combi 12/1100:	120 amp
Atlas Combi 12/1500:	160 amp
Atlas Combi 24/1800:	95 amp

Maximum input current:

Atlas Combi 12/1100:	330 amp
Atlas Combi 12/1500:	400 amp
Atlas Combi 24/1800:	270 amp

No-load in "auto" mode:

Atlas Combi 12/1100:	2.4 W
Atlas Combi 12/1500:	2.4 W
Atlas Combi 24/1800:	2.4 W

No-load in "on" mode:

Atlas Combi 12/1100:	20 W
Atlas Combi 12/1500:	20 W
Atlas Combi 24/1800:	25 W

Output

Output voltage: 230 V_{AC} 5%

Frequency: 50 Hz ± 1 Hz.

Waveform of output voltage: trapezoidal

Power factor: 0.9 capacitive to 0.4 inductive

Power at 20°C:

Atlas Combi 12/1100:	1100 W, power factor 1
Atlas Combi 12/1500:	1500 W, power factor 1
Atlas Combi 24/1800:	1800 W, power factor 1

Efficiency:	88% between 25% and 100% of connected power
Switch-on behaviour:	The inverter can start under any load conditions. The nominal output voltage is reached in 50 msec.

7.2 Automatic Economy Switch (AES)

Switch-on:	9 W
Adjustable sensitivity:	2 - 48 W
Switch-off:	5 W
Test voltage on "auto":	60 V _{rms} , 50 Hz
Power factor 1:	V _{in} 12 Volt
Dynamic stability:	Maximum surges of 10% when switching on and off at 50% nominal load. Recovery time is 1/2 period.
Overload protection:	The delivered power is limited electronically to: 12 V batteries: 170 % 24 V batteries: 200 % of the continuous power at the nominal input voltage.
Short-circuit protection:	The output is short-circuit proof.
The short-circuit current is:	
Atlas Combi 12/1100:	22 amp DC
Atlas Combi 12/1500:	25 amp DC
Atlas Combi 24/1800:	21 amp DC
Ambient temperature protection	Sensors measure the temperature of critical components. The sensors switch off the inverter if the temperature on the FET's rises above 80°C and/or the transformer temperature rises above 110°C. The inverter restarts automatically after the components have cooled down.

High/low input voltage protection: 12 V battery: The inverter switches off automatically at values above 17 V_{DC} and below 9.5 V_{DC}.
24 V battery: The inverter switches off automatically at values above 34 V_{DC} and below 18 V_{DC}.

7.3 Battery charger

Input

Nominal input voltage: 230 VAC
Frequency: 47-63 Hz
Input voltage range: 10 %
Input voltage fuse 230/240 V: 1 x 16 amp slow; 6.3 x 32 mm
Power factor: 0.7 inductive

Output

Nominal charging voltage:
Atlas Combi 12/1100: 12 V_{DC}
Atlas Combi 12/1500: 12 V_{DC}
Atlas Combi 24/1800: 24 V_{DC}
Boost/equalize charging voltage:
Atlas Combi 12/1100: 14.25 V_{DC}
Atlas Combi 12/1500: 14.25 V_{DC}
Atlas Combi 24/1800: 28.5 V_{DC}
Float charging voltage:
Atlas Combi 12/1100: 13.5 V_{DC}
Atlas Combi 12/1500: 13.5 V_{DC}
Atlas Combi 24/1800: 26.5 V_{DC}
Charging characteristic: IUoUo according to DIN 41772
Voltage stability: 1%
Output current:
Atlas Combi 12/1100: 40 amp
Atlas Combi 12/1500: 50 amp
Atlas Combi 24/1800: 35 amp

Changeover

Maximum switching capacity: 3500 W
Changeover time: 0.5 sec
Changeover delay: 30 sec approx.

Protection: slow glass fuse 20 amp 6.3 x 32 mm

7.4 Mechanical data

Noise level: 40 dB(A)
Cabinet: aluminium, seawater resistant
Protection: IP21
Colour: blue (RAL 5012), epoxy
Dimensions (H x W x D): 350 x 250 x 218 mm
Weight:
Atlas Combi 12/1100: 20 kg
Atlas Combi 12/1500: 20 kg
Atlas Combi 24/1800: 20 kg

Connecting points:
Output: 230 V_{AC} terminals 2.5 mm
12/24 V_{AC} output/input: M8 bolts
Starter battery, connection for trickle charger:
Output: 12 or 24 V_{AC} terminals 2.5 mm
Input: 230 V_{AC} terminals 2.5 mm
Earth: M4 screw (cabinet); 2.5 mm terminal on PCB
Cooling: regulated forced cooling
Relative humidity: maximum 95%

7.5 General

EMC:
Electro-magnetic compatibility according Council Directive 89/336 EEC
Emission EN 55014 (1993)
EN 60555-2 (1986)
Immunity EN 50082-1 (1991)

8. DRAWINGS

Complete Victron Energie system with Atlas Combi	p. 44
Victron Atlas Combi cabinet dimensions	p. 45
Victron Atlas Combi remote control connections	p. 46
Victron Atlas Combi connections	p. 47
Position Jumpers Atlas Combi	p. 48

